

# **pH/ORP-3500**

## **pH/ORP Transmitting controller**

**Operation manual**

V1.1

## Introduction

Thanks for choosing pH/ORP-3500 series pH/ORP meter. Please read the operation manual carefully before installation. Proper sensor installation and parameter setting would give maximum performance and advantage of this instrument for your good usage. So please carefully read this manual before installation.

This instrument is a precise electrochemical analysis Dosing &Control Integration System, which should be operated by technicians with relevant professional knowledge.

Please contact technical backup when you meet any problems during installation and usage.

Check the actual product with complete set after you receive the package, and contact us if any missing or damage.

Our serious promise:

1. The meter's quality guarantee is one year from the date of purchasing. During this period, if the meter has quality problems, manufacturer is responsible for maintenance for free or replacement.

2. We provide lifelong maintenance service for the product whatever you purchase from us or distributors.

3. If the damage of the meter is caused by the following reasons, it is out of the maintenance service:

A).The meter is burned caused by misconnection with high voltage power supply or soggy.

B).The meter is refitted or misused without permission.

C).The meter is damaged under the condition out of use environment.

D).The relevant damage caused by choosing the wrong type.

E).The physical damage caused by ultimate load

F).The meter is out of operation caused by improper storage and transportation (refer to SJ/T10463-93 standard)

G).Consumable material is out of maintenance service.



Please take care of the items which with this sign. !

\*Without the influence on the operation, any small change or improvement on the products by the manufacturer will not be notified separately. Please make the object as the standard

## Content

I、 GENERAL.....	1
1.1 WORKING PRINCIPLE.....	1
1.2 APPLICATION.....	1
1.3 CLASSIFICATION.....	2
1.4 TECHNIQUE INDEX.....	3
II、 INSTALLATION.....	4
2.1 INSTALLATION OF INSTRUMENT.....	4
2.2 ELECTRICAL CONNECTION.....	5
2.3 DIAGRAM OF 4-20MA OUTPUT.....	6
2.4 RELAY CONTROL CONNECTION.....	7
2.5 CONTROL MODE.....	7
2.6 INSTALLATION OF SENSOR.....	8
2.6.1 ASSEMBLING AND REPLACEMENT.....	8
2.6.2 INSTALLATION METHOD.....	9
2.6.3 INSTALLATION REQUIREMENT.....	10
III、 SETTINGS.....	10
3.1 MEASUREMENT MODE.....	12
3.1.1 NORMAL DISPLAY.....	12
3.1.2 TRANSIENT DISPLAY.....	12
3.2 SETTING MODE.....	12
3.2.1 FUNCTION SELECTION.....	13
3.2.2 4MA SETTING.....	13
3.2.3 20MA SETTING.....	13
3.2.4 HIGH-LIMIT ALARM SETTING.....	13
3.2.5 LOW-LIMIT ALARM SETTING.....	13
3.2.6 ALARM HYSTERSIS SETTING.....	14
3.2.7 TEMPERATURE SETTING.....	14
3.3 SENSOR CALIBRATION.....	14
3.3.1 SYSTEM CALIBRATION.....	14
3.3.2 BUFFER SOLUTION CALIBRATION.....	14
3.3.3 OFF-LINE CALIBRATION.....	15
IV、 MAINTENANCE.....	16
4.1 SENSOR MAINTENANCE.....	16
4.2 USAGE OF SENSORS.....	16
V、 TROUBLE SHOOTING.....	17
VI、 COMPLETE SET.....	17
VII、 ORDER DIRECTORY.....	18
7.1 SENSOR SELECTION.....	18
7.2 FLOW DEVICE SELECTION.....	18

## I .GENERAL

pH/ORP-3500 series is a kind of popular and cost-effective online pH and ORP controller , with plug-in pH/ORP-1220 sensor, which have good measurement accuracy, anti-interference,easy to install and operation features.

- White backlight LCD screen,several operations, easy for operation
- Be compatible for six kinds of buffer solution(10.00,9.18,7.00,6.86,4.00,4.01) which suitable for international standard.
- Selectable temperature sensor which reduce the replacement cost.



- Manual calibration is easy for on-site calibration.
- EMC enhancement type could run smoothly under kinds of industry environment.
- (4~20) mA output support instrument/transmitter modes and satisfy all (4~20) mA receiving unit.
- Double relay high/low and delay control function could fulfill pH or ORP interval control and adjustment.
- Several power supply to be selection according to the different models.Input AC/DC power, no polarity connection.

### 1.1 Working Principle

The weak voltage change is generated when  $H^+$  affected the inserted sensor, the changeable value will transmit to the instrument. After converting and calculating the generated pH/ORP signal, the instrument will show the values on the screen.

### 1.2Application

This series instruments are widely used for online pH/ORP monitoring in environment protection water treatment, pure water treatment, industrial process and so on.

### 1.3 Classification

model	Power supply	frequency (Hz)	Current mode	Sensor selection
pH/ORP-3500	DC 24V	-----	Instrument/transmitter	pH-1220B plug-in sensor; ORP-1220B plug-in sensor or other sensors; TE-1230-14 temperature sensor
pH/ORP-3510	AC 110V	50/60	Instrument/transmitter	
pH/ORP-3520	AC 220V	50/60	Instrument/transmitter	

#### 【NOTE】

1. Put the instrument in dry environment and the water-drop or moisture will cause the damage or measurement error ;
2. Pay more attention on the power supply before wiring connection.

## 1.4 Technique index

model		pH/ORP-3500series pH/ORP online transmitting controller
Measurement range	pH	0.00~14.00
	ORP	-2000mV~2000mV
	Temp.	(0.0~50.0) °C (temperature compensation component: NTC10K)
Resolution	pH	0.01
	ORP	1mV
	Temp	0.1°C
accuracy	pH	0.1 level
	ORP	±5mV (electronic unit)
	Temp	±0.5°C
Approximate input impedance		$3 \times 10^{11} \Omega$
Buffer solution		10.00; 9.18; 7.00; 6.86; 4.01; 4.00
Temp. compensation range		(0~50) °C (with 25°C as standard) Manual and automatic temperature compensation
(4~20)mA	characteristics	Isolated,fully adjustable,reversible,instrument/transmitter for selection
	Loop resistance	500Ω (Max), DC24V
	accuracy	±0.1mA
Control contact	Electrical contacts	Double relay SPST-NO, hysteresis model
	Loop capacity	AC220V/AC110V 2A(Max); DC24V 2A(Max)
Power consumption		< 3W
Working environment	temperature	(0~50) °C
	humidity	≤85%RH(none condensation)
Storage environment		Temp.(-20-60) °C;relative humidity:≤85%RH(none condensation)
Outline dimension		48mm×96mm×80mm (H×W×D)
Hole dimension		44 (H) mm×92 (W) mm
installation		Panel mounted,fast installation

## II、INSTALLATION

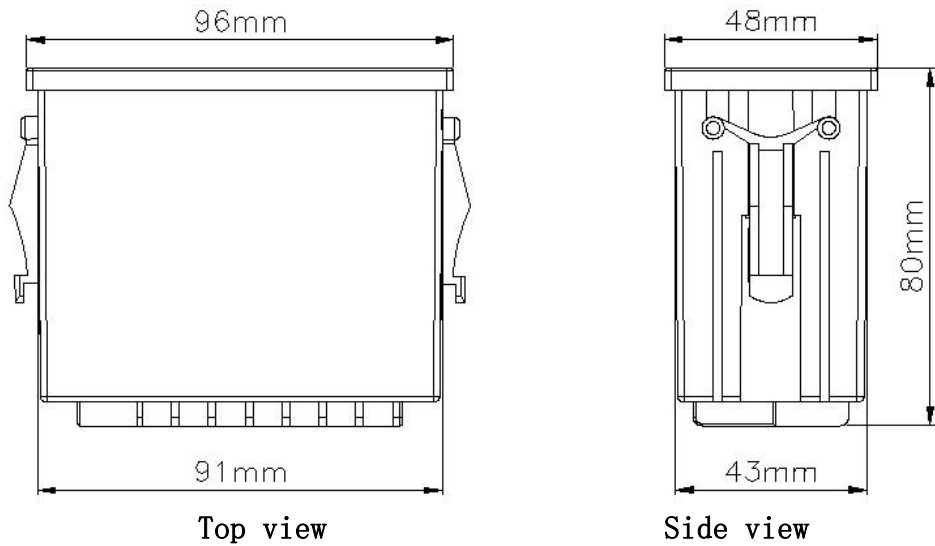

### 2.1 Installation of instrument

pH/ORP-3500 series is adopted panel mounted type, which could be installed easily. Please follow the steps:

1. Put the instrument into the fixed hole 44mmX92mm(HxW)
2. Then push the quick clamp along with the trench and fasten the instrument.

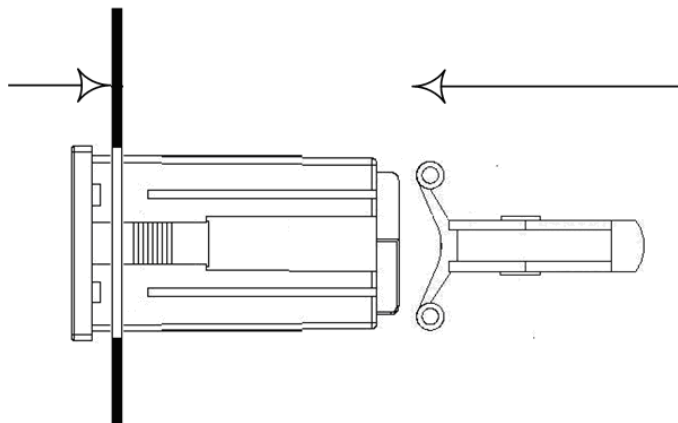

3. Do not let the instrument drop on the floor when dismantling the meter. Withdraw the quick clamp and take the instrument down.



Do not put the instrument under the sun since the UV will damage the LED screen.

## 2.2 Electrical Connection

The measurement cable can not be mixed with high-pressure and high frequency cable. To avoid any interference, the cables should be 30cm distance and connect with the ground.

Connect the power line and signal line according to the below diagrams:



pH/ORP-3500 rear terminal



pH/ORP-3510 rear terminal



pH/ORP-3520 rear terminals

Wiring connection:

0V/220V	AC 220V input interface (pH/ORP-3520)
0V/110V	AC 110V input interface (pH/ORP-3510)
24VA/B	DC 24V input interface (pH/ORP-3500) ( Internal automatic recognition of polarity )
	Electromagnetic compatibility group protection terminal
Hi	High limit alarm control terminal blocks
Low	Low limit alarm control terminal blocks
T-	(T+, T-) transmitting mode external feed
T+/I-	Transmitting /Instrument Mode public terminal
I+	(I+, I-)Instrument mode mA output terminal
TEMP-I	Connect the receiving terminal of the temp.sensor(red)
TEMP-G	Connect grounding terminal of the temp. sensor (black)
NC	Empty terminal
BNC connector	Connect pH or ORP sensor



### 2.3 Diagram of 4-20mA output

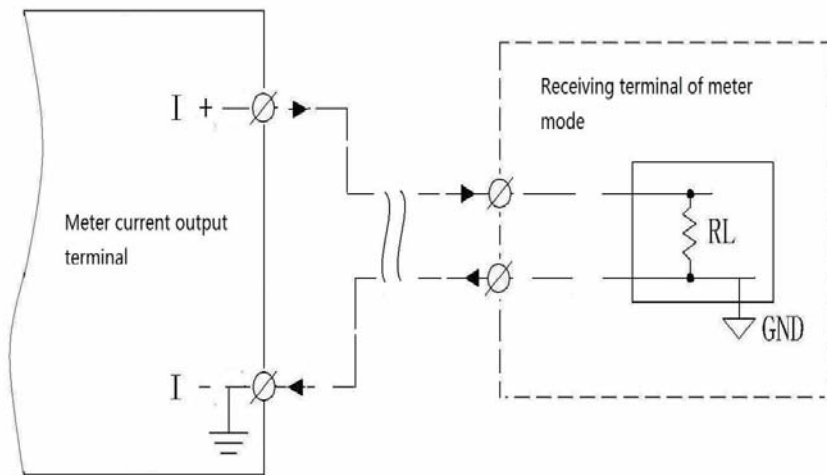

#### Instrument mode

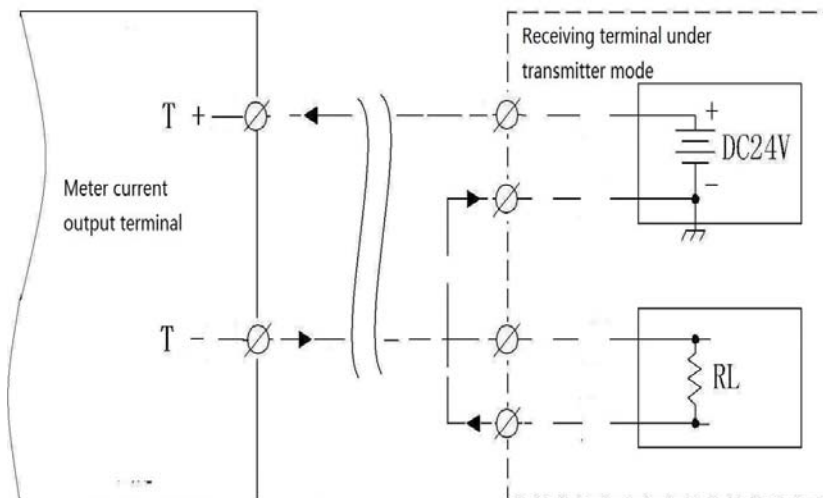

#### Transmitting mode

## 2.4 Relay control connection

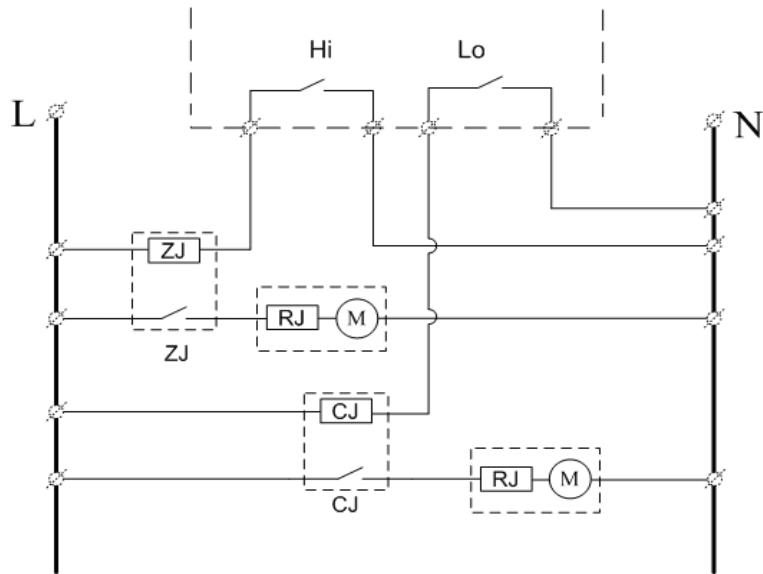

Relay ON/OFF contact component control wiring diagram

## 2.5 Control mode

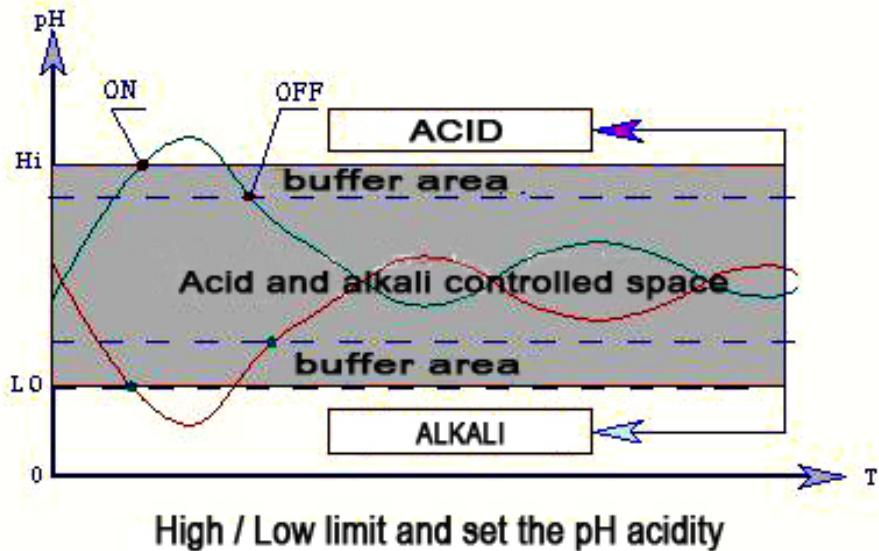

## 2.6 Installation of sensor

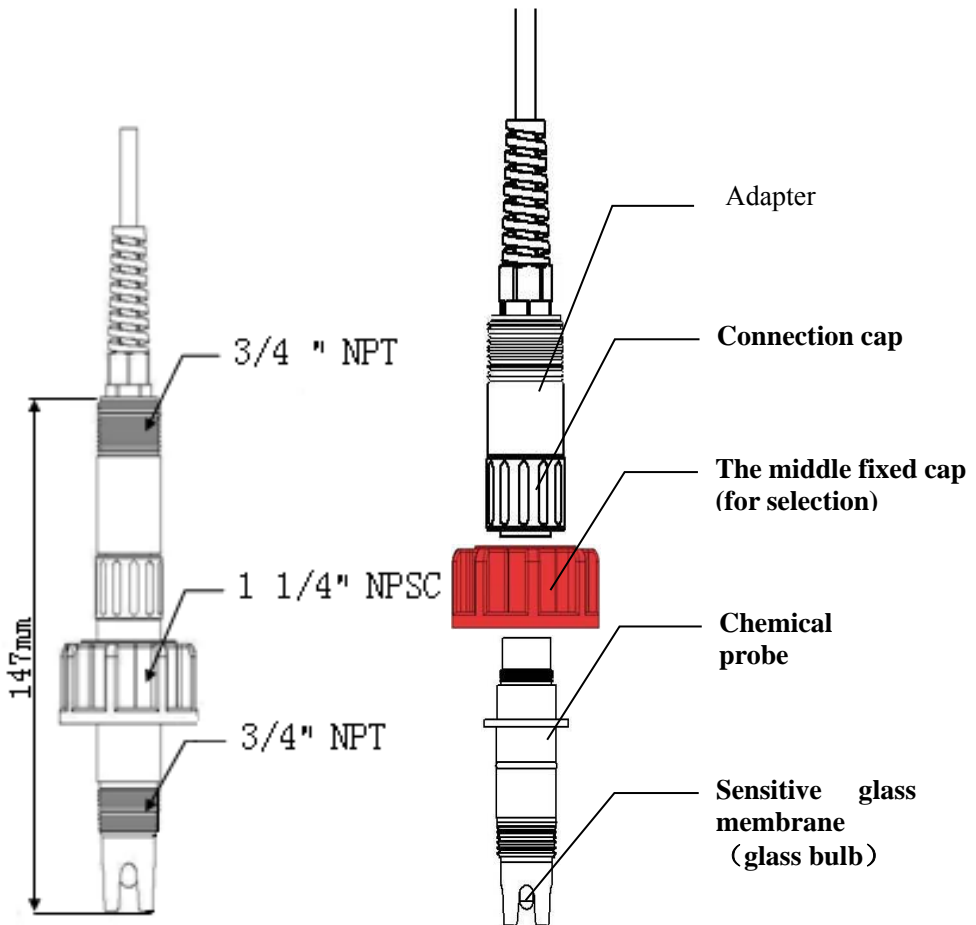

### 2.6.1 Assembling and replacement

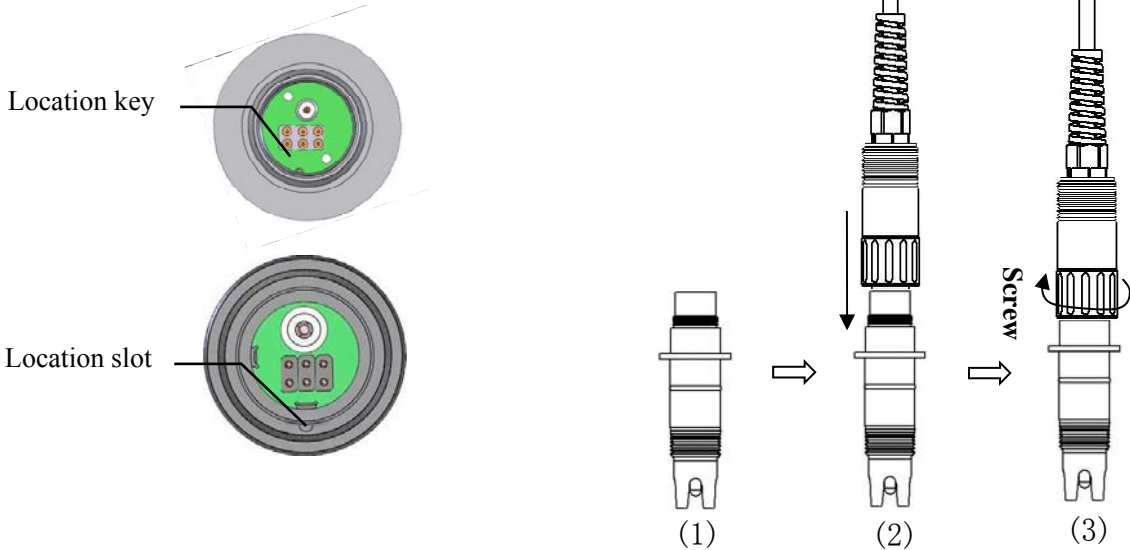



The location key and location slot must be occlusive exactly. No rough installation.

### 2.6.2 Installation method

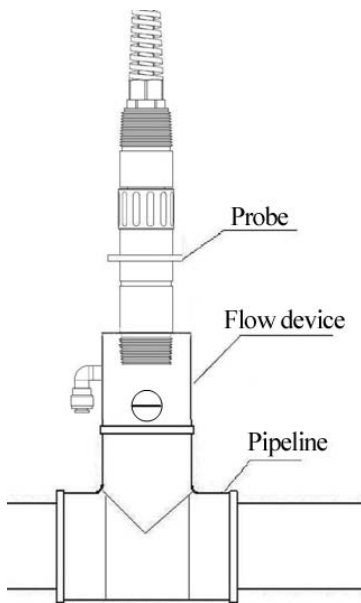

Flow device P34A

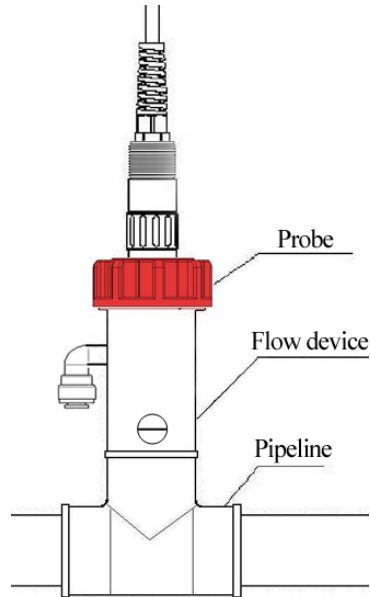

Flow device P34B



**[Note]** : Recommend using the flow device with needle valve (P34)

1. Needle valve flow device (model P34A/B) is recommended when pipeline installation, which can change probe under pressure-bearing, continue condition;
2. Round sensitive glass steep pH probe direct install in the pipeline, it will threaten the probe when the pipeline pressure change, water hammer or siphon effect, after using flow device, the probe and atmosphere will communicate, operational states safe and measure stability
3. When direct install pipeline, pure water measurement value will instability because the water is weak electrolyte, sensitive glass film (glass bubble) and salt bridge present discontinuity open circuit, result the measure value instability
4. When direct install the pipeline to measure pure water, high concentration KCL of pH probe and pure water form huge concentration difference, trough liquid abutment spread into the water largely. Cause the probe lose effectiveness, pollute the pure water meantime., make the conductivity under probe downstream of pH probe rise hugely.

### 2.6.3 Installation requirement



Middle 1 1/4 " NPSC straight pipe thread fitting Upright install or slant install no more than 30°

bottom 3/4 " NPT taper thread fitting; Upright install or slant install no more than 30°



Horizontal installation does not work



Backward installation does not work

### III、 SETTINGS

You could set the relative parameter after connect the instrument and sensor. Please enter into the setting mode to check and set the relative parameters for your first use. These parameters are in different menus.



### Main Menu

Please operate the meter with the keys. Under the different mode, the function will be different.

Sign	Name	Function
»»	SELECT	<ol style="list-style-type: none"> <li>1. check the temp. compensation value under pH measurement status</li> <li>2. exit or skip the setting parameter</li> <li>3. select thousand, hundred ,ten and unit circularly under parameter setting interface</li> <li>4. long-time press the key under pH measurement status, it will enter into pH mV calibration interface</li> </ol>
^^	Add key	<ol style="list-style-type: none"> <li>1. set the 0-9 figure under parameter setting status</li> <li>2. long-press the key under pH measurement status, it will enter into the buffer calibration interface.</li> <li>3. check mV value under pH measurement status.</li> </ol>
↶	Enter key	<ol style="list-style-type: none"> <li>1. enter into the main menu</li> <li>2. save the parameter settings</li> </ol>

Three functions shows on the main interface: the upper icon is menu bar which guide the operation; the left area displays the measurement unit of the current time; the value means the measurement data or menu items.

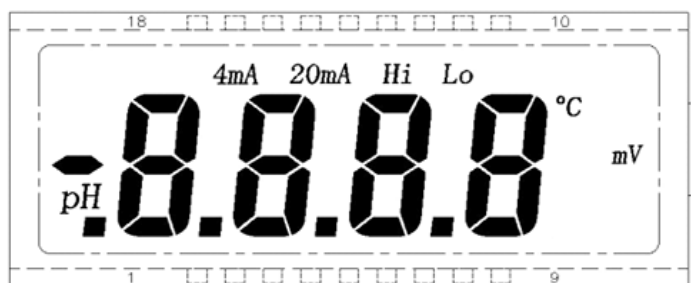

pH/ORP-3500 working mode :

- ◆ Measurement mode : Normal display、transient display
- ◆ Setting mode : Parameter setting

Switch the mode as following :

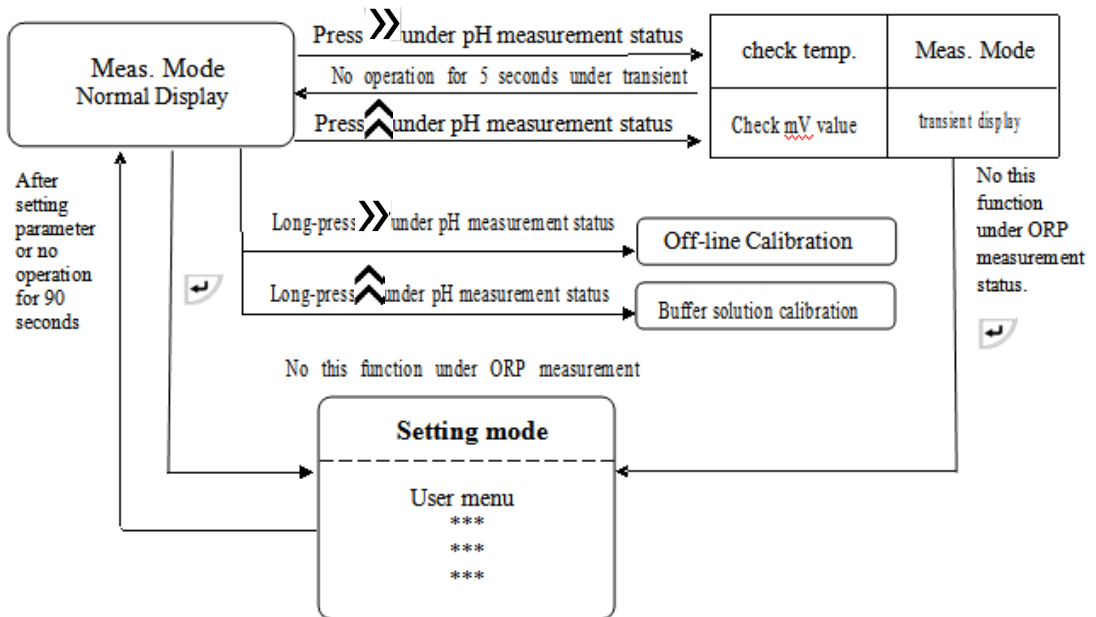

### 3.1 Measurement mode

#### 3.1.1 Normal display

The instrument will display the current pH/ORP value after powered on.

#### 3.1.2 Transient display



Under pH measurement status, check the current temperature by pressing >>, and check the mV value by pressing <<. It will return to normal display without operation for five seconds

### 3.2 Setting mode

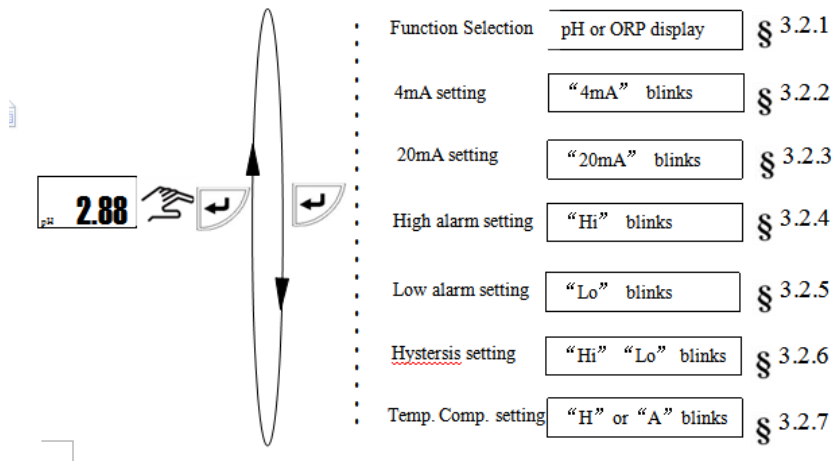

Some parameters have been set before ex-factory. If the test environment changes (such as replacement of electrode, reset the alarm setting), please check the parameter which is in different menus. The specific content and operations as following :





### 3.2.1 Function selection

Choose "pH" or "ORP" function selection by pressing  and press  for saving the setting and enter into the next parameter setting.



### 3.2.2 4mA setting

When the screen displays "4mA", press  to select the digital position and input the actual pH/ORP value by pressing , and save and enter into the next menu setting by pressing .

### 3.2.3 20mA setting

When the screen displays "20mA", press  to select the digital position and input the actual pH/ORP value by pressing , and save and enter into the next menu setting by pressing .

### 3.2.4 High-limit alarm setting

The screen will displays "Hi" after entering the interface of high-limit alarm setting, press  to select the digital position and input the actual value by pressing , and save and enter into the next menu setting by pressing .

### 3.2.5 Low-limit alarm setting

Same operation as the high-limit alarm setting, and press  after setting.



### 3.2.6 Alarm Hysteresis setting

When “Hi” and “Lo” appear at the same time, set the pH/ORP hysteresis value by pressing “>>>” and “^”. Save and enter into the next menu.

 The MIN value: pH > 0.1; ORP > 10mV!

### 3.2.7 Temperature setting

When “H” or “A” blinks, press “^” to do the manual temperature compensation (H25.0°C) or automatic temperature compensation (A25.0°C) (automatic temperature compensation need to connect a temp. sensor NTC10K.). Then save and return to measurement status.

 **NO THIS OPERATION FOR ORP MEASUREMENT!**

## 3.3 Sensor calibration

### 3.3.1 System Calibration

pH/ORP sensors are electrochemical and their sensitivity decreases with influence of time and medium. In order to get an accurate measurement, it is suggested to often calibrate sensor's slope. The calibration period relays on the influence from the measured medium

- 1) Normal buffer solution ,10.00\9.18\7.00\6.86\4.00\4.01
- 2) If the medium are acid or alkali, please choose two point slope calibration, use two kind buffer solution.
- 3) Before the calibration, please read the instruction carefully , and prepare the standard buffer solution
- 4) The meter with directly input calibration method, please reference the calibration steps.
- 5) If the sensor with long time storage, please put it in the water or KCL solution for 12 hours , and then calibrate it.

### 3.3.2 Buffer solution calibration

1. Choose the correct buffer solution to calibrate. ;
2. Press the ^ for 3 seconds and enter into buffer solution calibration interface under pH measurement interface, input the current temperature , save and enter into buffer solution calibration by pressing ↩.
3. When the “C10.0” and pH blinks, it means to enter into the buffer solution selection; press “>>>” and enter into the next calibration menu.
4. Put the clean sensor into the buffer solution for 3-5 minutes.

5. Press “↩” to save the settings and enter into the next calibration, fetch the sensor out and clean, then put it into the suggestive buffer solution and finish the calibration in turn.
6. Check the buffer solution and recalibrate when “ERRO” comes out and then recalibrate.

Please follow the below detailed calibration process:

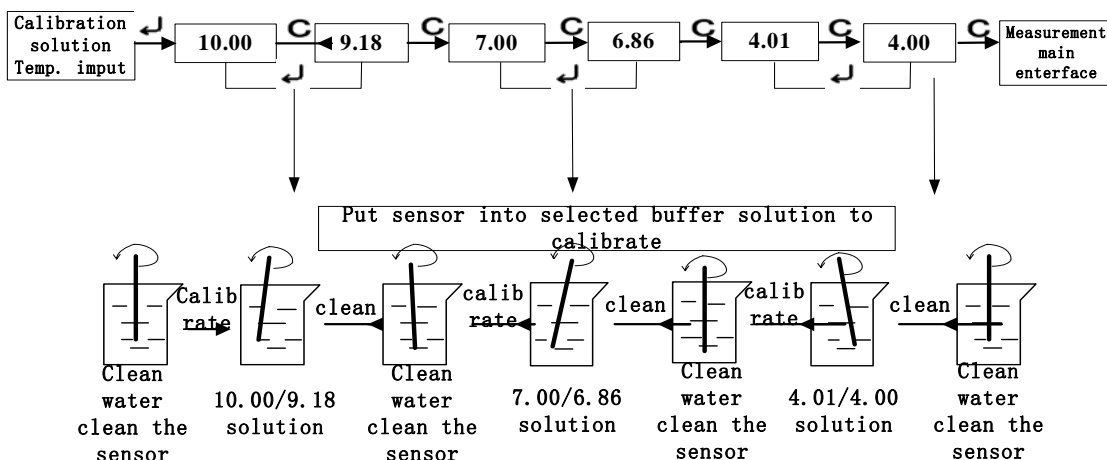

⚠ **C** means skip this operation; and ↩ means enter the operation.

### 3.3.3 OFF-LINE CALIBRATION

When field calibration is not good to carry on, the calibration to sensor's slope by using lab devices and buffer solution is recommended. Take notes of corresponding mV value of buffer solution in room temperature. Input of this record value to off-line calibration is called as manual input calibration.

Press “>>” for 3 seconds under pH measurement status, input the corresponding mV value in different buffer solution, press “↩” to save and enter into the main menu.

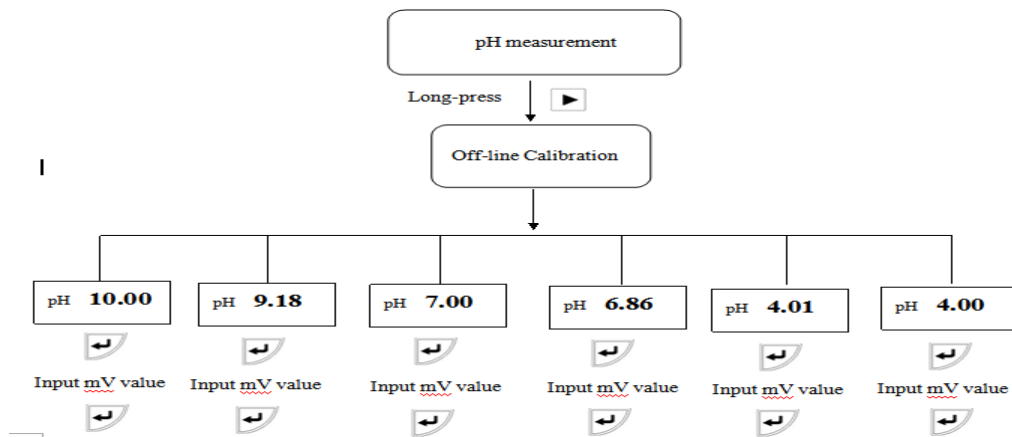

Incorrect mV value input during calibration process, the screen will display “E-1” .

Press “↩” to continue the calibration, and press “>>” to enter into the next calibration.

## IV、 MAINTENANCE

### 4.1 Sensor Maintenance.

1. To avoid long time dry store, the sensor should be kept in the protection cap with KCl solution in 3.0mol/L. ;
2. Clean the sensor and calibrate the same on the indicator regularly. ;
3. In case of suspended stuff attached, wash it with HCl or NaOH solution in 0.01mol/L and rinse with clean water ;
4. If the above methods are invalid to reset slope, it means that the sensor should be replaced. ;
5. The platinum surface of ORP sensor should be shining. In case of smudginess, wash it with HCl or NaOH solution in 0.01mol/L and rinse with distilled water. If the surface of platinum is polluted and formed oxidation film, the platinum could be polished with sand paper and toothpaste, then clean it with distilled water ;
6. Place the sensor into 3.5 mol/L KCl solution for 6 hours before usage ;
7. Buffer solution gets different value at different temperature so please confirm the temperature of buffer solution at calibration.

### 4.2 Usage of sensors

1. pH/ORP sensors are consumables .Long time storage is not suggested;
2. Sensitive glass film (glass bubble) is forbidden to use when the medium with hydrofluoric acid, fluorion and high-concentration sulfion.
3. pH/ORP sensors are not allowed to measure any organic solution which will

- damage or dissolve PC or ABS(such as carbon tetrachloride, trichloro ethylene or tetrahydrofuran etc....);
4. The chemical part of the sensor is glass, please protect carefully during transportation and storage.
  5. Please clean the sensor at a regular time by using swab and neutral cleanser; do not use the acid and corrosive solution to clean the sensor.
  6. High-temp. pH glass sensor is recommended for biopharmacy and high-pressure autoclaved sterilization. The protection part is optional;
  7. pH signal is weak signal, the collecting cable should run separately. Do not mix the cable together.
  8. Measurement cable is for special use, it's not allowed to cut or lengthened privately or replaced by other cables.;
  9. Install a filter before sensor when there is molecule in the medium to protect the pH glass bubble.

## V、 TROUBLE SHOOTING

Problem	Possible causes	Trouble shooting
No display when powered on	A. Bad connection of power supply B. Instrument fault	A check to see if there is 24Vvoltage between power terminals 24VA and 24VB. B. Check by professional technicians.
Unstable display	A. Improper wire connection of sensor B. Air bubbles in the pipeline C. Unstable water quality D. badness connection	A. refer to the instruction manuals B. select the proper measurement point or change the pipeline C. stabilizing the water quality D. Check the connector to be connected
Big deviation	A. Sensor fault B. The cable is damaged C. incorrect installation D. setting problem	A. Take out the sensor from the pipeline and calibrate B. replace the sensor which can not be calibrated C. find the correct measurement point and use the flow device D. reset the parameter of the instrument
Difference at transmitting data	A. loop resistance is too large B. incorrect connection mode C. unusual power supply D. wrong transfer volume	A. replace the cable to reduce the loop resistance B. check the connection right or not C. powered by the standard D. reset the transferred volume

## VI、 COMPLETE SET

Transmitter	1pc (including quick clamp)
pH/ORP-1220B sensor	1pc (cable length 10m)
Operation manual	1pc
Certificate	1pc

## VII、 ORDER DIRECTORY

Choose the right power supply, sensor and flow device to meet the requirements before ordering according to the below table:

### 7.1 Sensor selection

Model	Power supply	sensor	Cable length
pH/ORP-3500	DC 24V	pH-1220B sensor	1m
pH/ORP-3510	AC 110V	ORP-1220B sensor	5m
pH/ORP-3520	AC 220V	TE-1230-14 temp. sensor	10m (standard)
			20m
Other sensor selection	High-temp. glass sensor High-pure glass sensor		

### 7.2 Flow device selection

Quote the instrument/sensor/flow device separately, different price for different selection

Flow device	sensors	applications
P33 flow device	pH/ORP0410 glass sensor	Automatically controller or lab system
P34A flow device	pH/ORP1220B sensor	Pipeline installation
P34B flow device	pH/ORP1220B sensor	Pipeline installation
P16 used for submersible installation	P202/203 sensor	Channel or reservoir
P17 used for flange installation	P202/203 sensor	reaction still or material tank
Accessories for fold	P202/203 sensor	Wastewater pool oraeration tank

<https://chemitech.id>

order via whatsapp: +6282366660856

submersible installation		
Floating accessories	P202/203 sensor	Channel, river aquacultural
Jacket (protection part)accessories	High temp. glass sensor	Bio-pharmaceuticals and foodfermentation
Noble metal protection	pH/ORP1220B sensor	Metallurgy or floatation system